

STAMBENA GRAĐEVINA UVALA LJUBLJEVA-VINIŠČE

KUĆA ISTOK

KUĆA SREDINA

KUĆA ZAPAD

# 1. SITUACIJA PRIZEMLJE



# 2. SITUACIJA 1. KAT

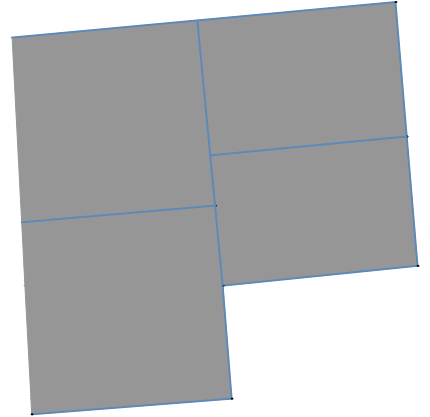
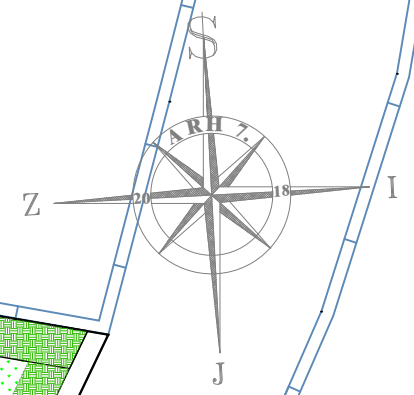

KOLNI PRISTUP

# 3. SITUACIJA KROV

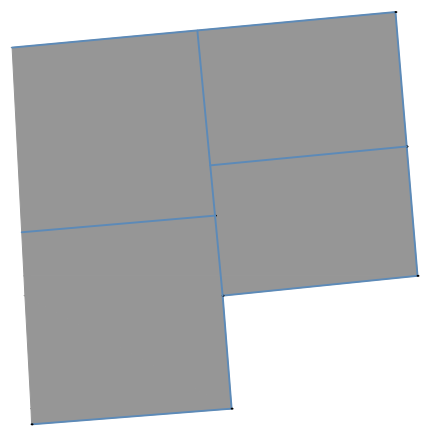
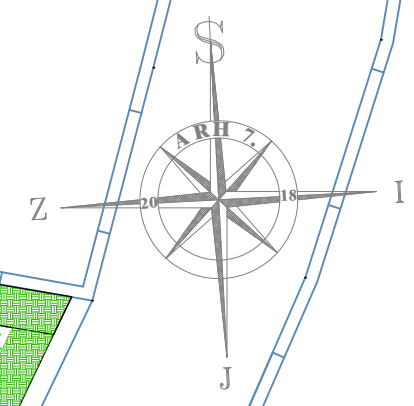

# 7. KUĆA ZAPAD

TLOCRT PRIZEMLJA

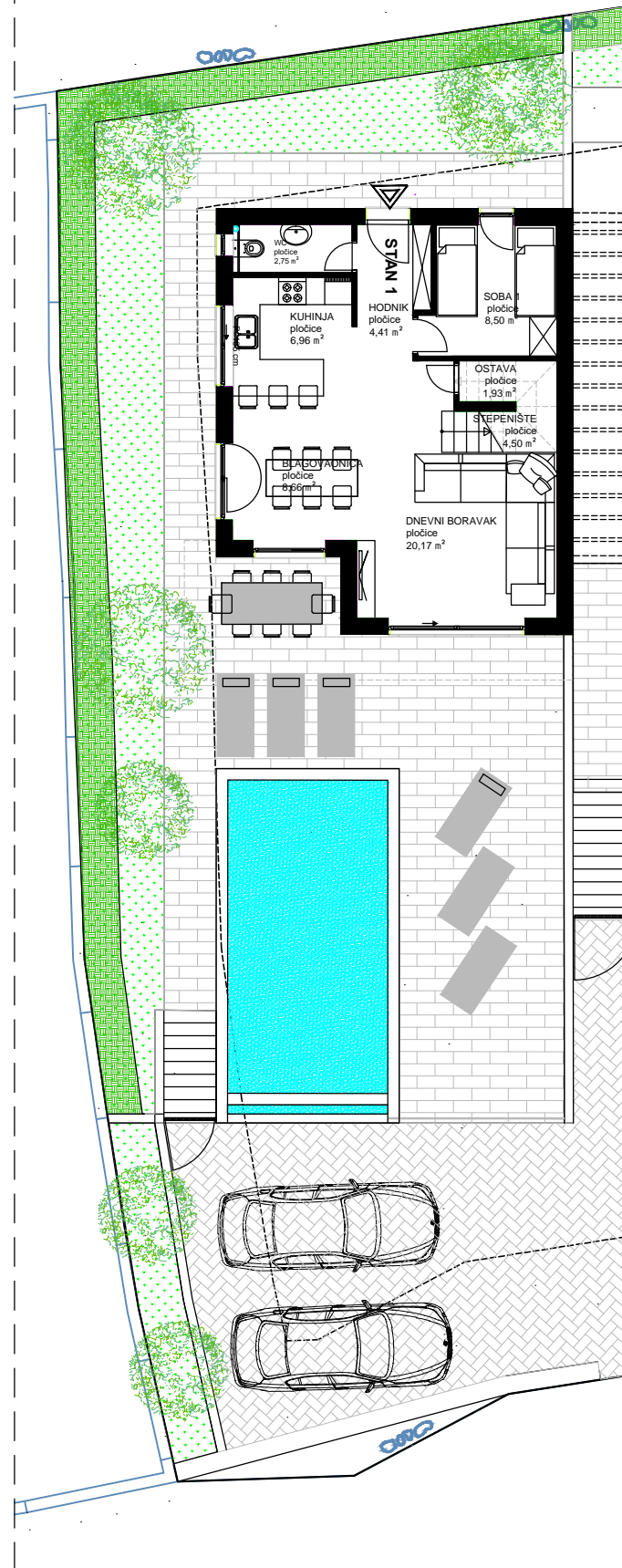

TLOCRT 1. KATA

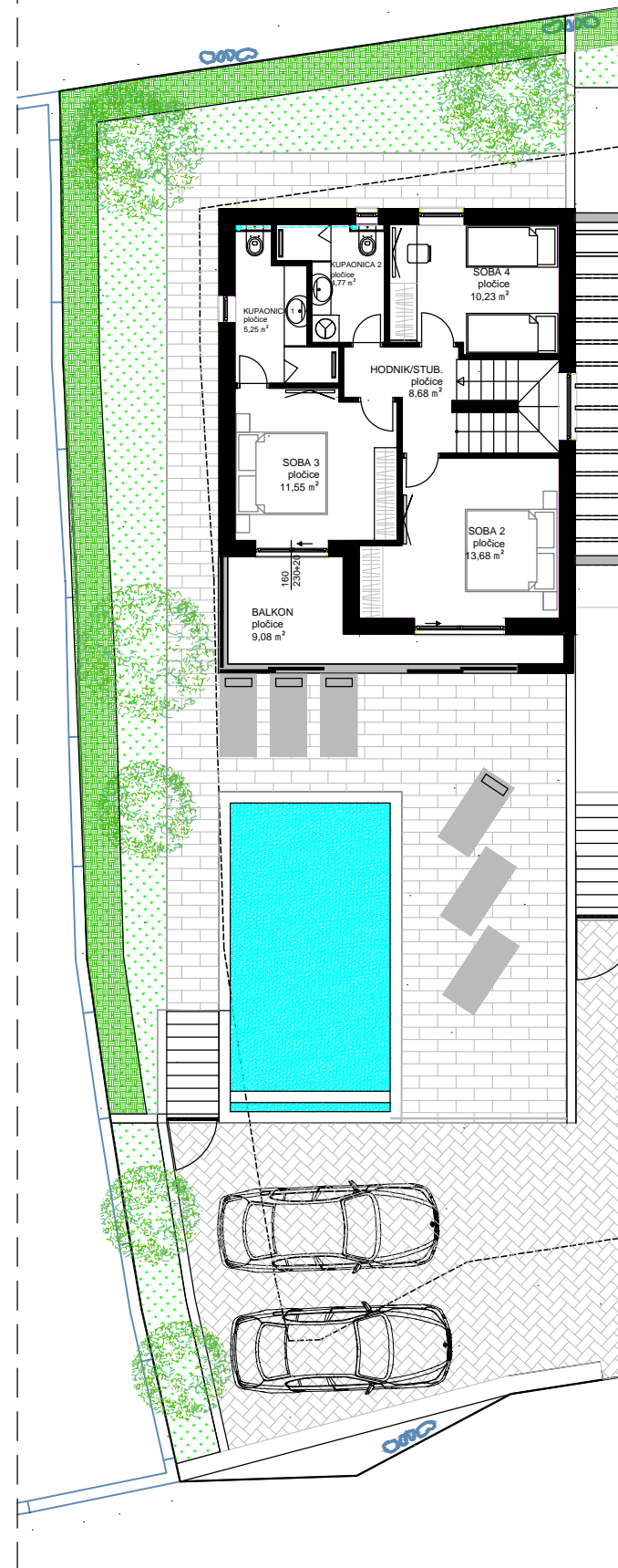

TLOCRT KROVA

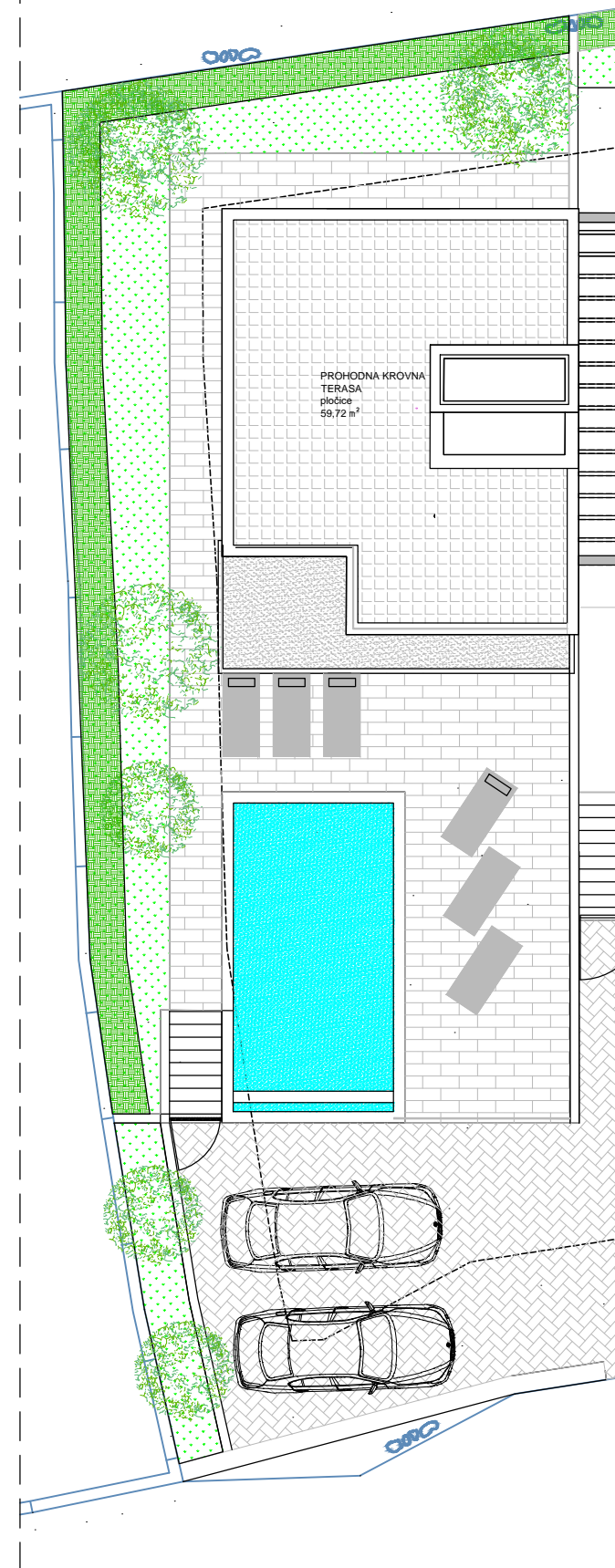

ISKAZ POVRŠINA KUĆA ZAPAD						
Prostorija	Netto (m <sup>2</sup> )	Koef.	NKP (m <sup>2</sup> )	Brutto (m <sup>2</sup> )	GBP (m <sup>2</sup> )	
PRIZEMLJE	Hodnik	4,41	1	4,41		
	Wc	2,75	1	2,75		
	Soba 1	8,50	1	8,50		
	Kuhinja	6,96	1	6,96	68	68
	Blagovaonica	8,66	1	8,66		
	Dnevni boravak	20,17	1	20,17		
	Ostava	1,93	1	1,93		
Stepenište	4,50	1	4,50			
1. KAT	Stepenište/hodnik	8,68	1	8,68		
	Soba 2	13,68	1	13,68		
	Soba 3	11,55	1	11,55		
	Kupaonica 1	5,25	1	5,25	68	68
	Kupaonica 2	4,77	1	4,77		
	Soba 4	10,23	1	10,23		
	Balkon	9,08	1	9,08		
Stepenište	4,50	1	4,50			
KROV	Krovna terasa nenatkriv	59,72	0,25	14,93	68	-
	VRT	popločana terasa u vrtu	88,00	0,2	17,60	-
	vrtni	64,80	0,1	6,48	-	-
BAZEN	Bazen	25,55	0,25	6,39	31,08	-
PARKING	2x parkirna mjesta	25,00	0,2	5,00	-	-
Ukupno prizemlje:		388,69		176,02	235,08	136,00

# 6. KUĆA SREDINA

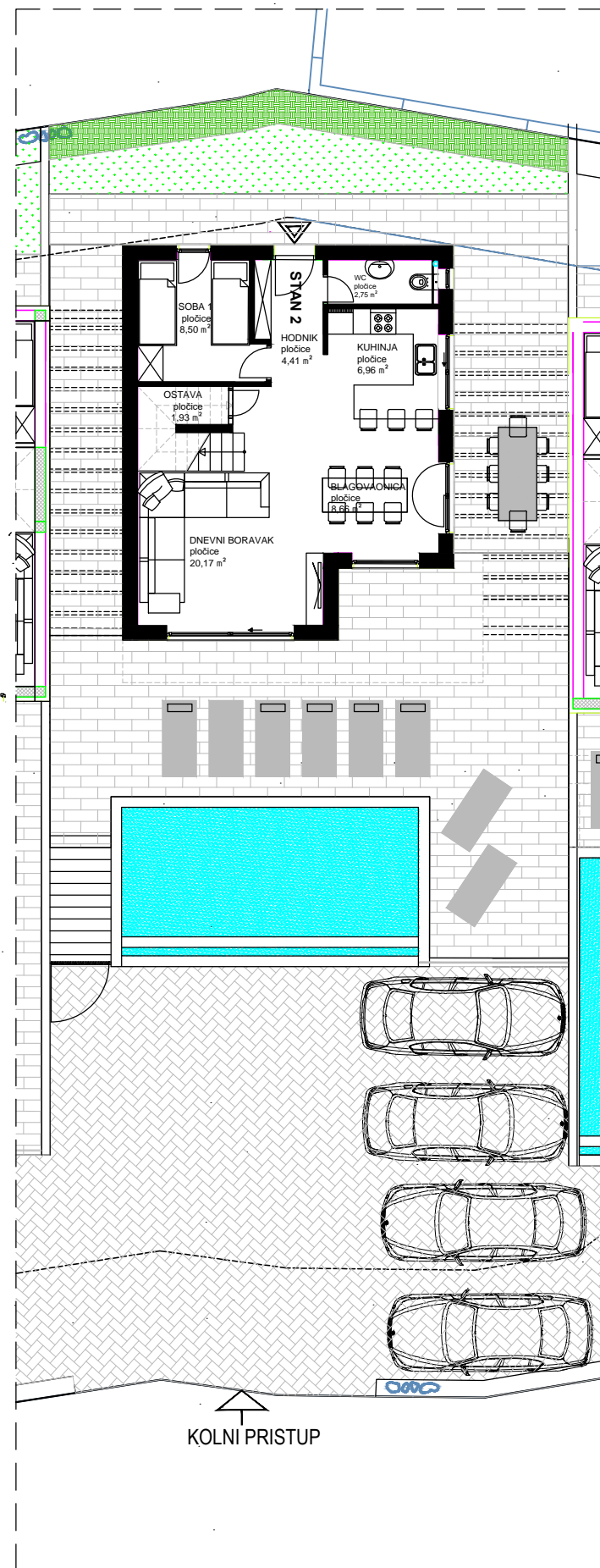

TLOCRT 1. KATA

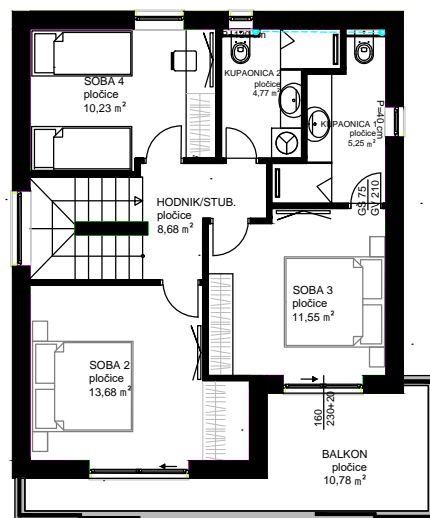

TLOCRT KROVA

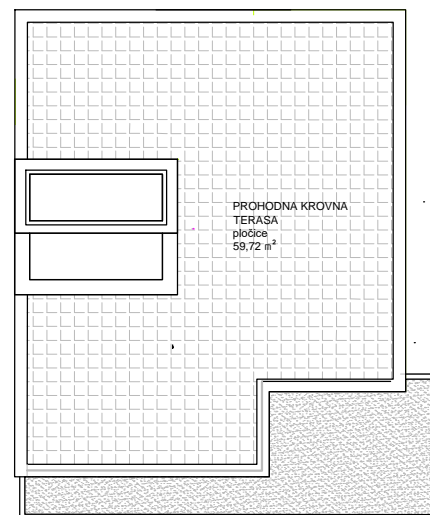

ISKAZ POVRŠINA KUĆA SREDINA					
Prostorija	Netto (m <sup>2</sup> )	Koef.	NKP (m <sup>2</sup> )	Brutto (m <sup>2</sup> )	GBP (m <sup>2</sup> )
<b>PRIZEMLJE</b>					
Hodnik	4,41	1	4,41		
Wc	2,75	1	2,75		
Soba 1	8,50	1	8,50		
Kuhinja	6,96	1	6,96	68	68
Blagovaonica	8,66	1	8,66		
Dnevni boravak	20,17	1	20,17		
Ostava	1,93	1	1,93		
Stepenište	4,50	1	4,50		
<b>1. KAT</b>					
Stepenište/hodnik	8,68	1	8,68		
Soba 2	13,68	1	13,68		
Soba 3	11,55	1	11,55		
Kupaonica 1	5,25	1	5,25	68	68
Kupaonica 2	4,77	1	4,77		
Soba 4	10,23	1	10,23		
Balkon	9,08	1	9,08		
Stepenište	4,50	1	4,50		
<b>KROV</b>					
Krovna terasa nenatkriv	59,72	0,25	14,93	68	-
<b>VRT</b>					
popločana terasa u vrtu	124,00	0,2	24,80	-	-
vrt	25,00	0,1	2,50	-	-
<b>BAZEN</b>					
Bazen	24,5	0,25	6,13	31,08	-
<b>PARKING</b>					
2x parkirna mjesta	25,00	0,2	5,00	-	-
<b>Ukupno prizemlje:</b>	<b>383,84</b>		<b>178,98</b>	<b>235,08</b>	<b>136,00</b>

# 5. KUĆA ISTOK

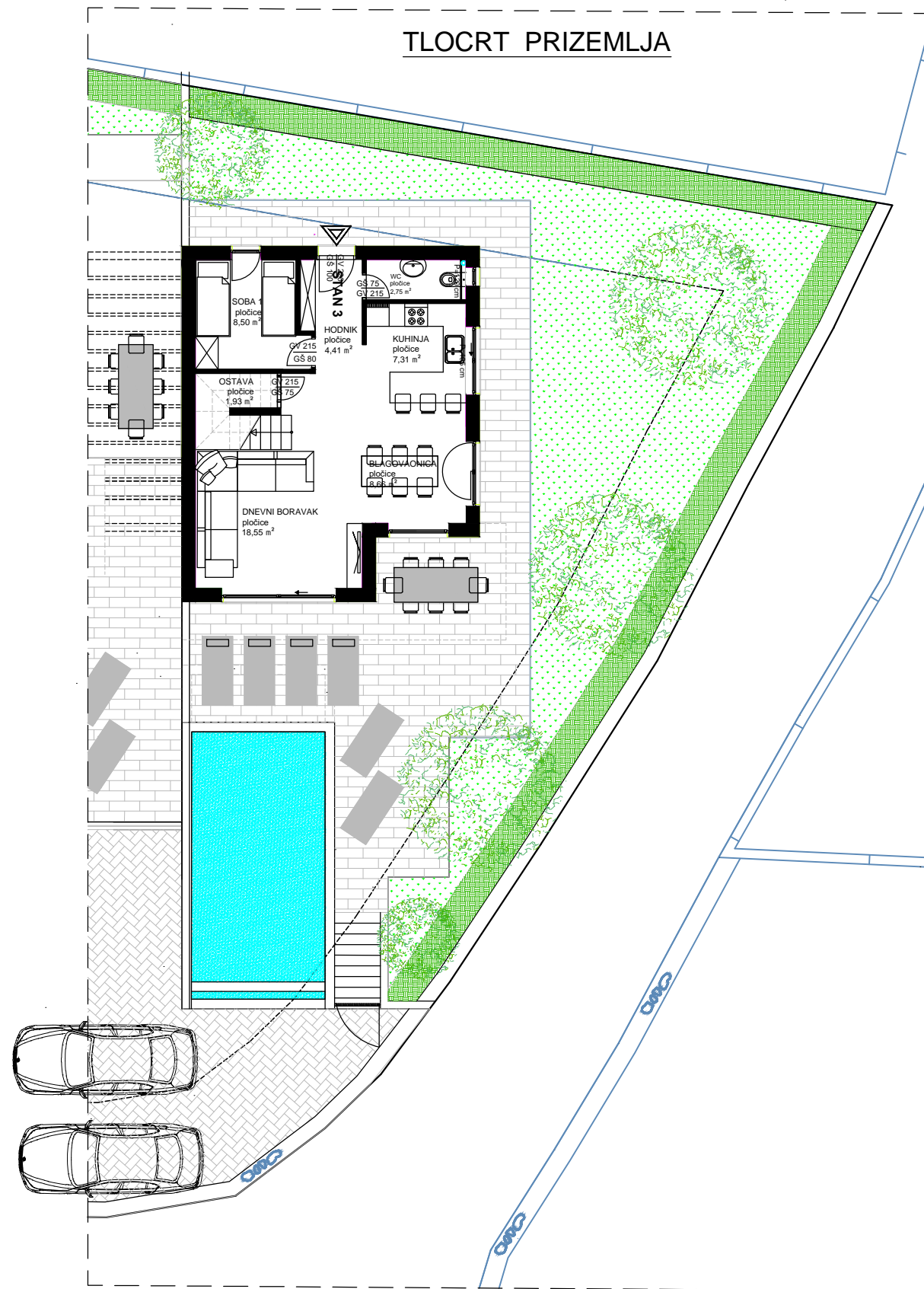

## TLOCRT 1. KATA

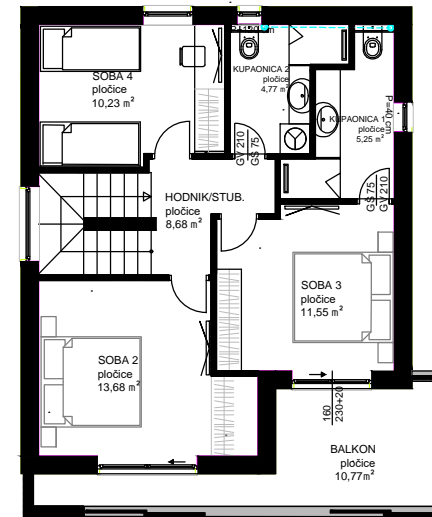

## TLOCRT KROVA

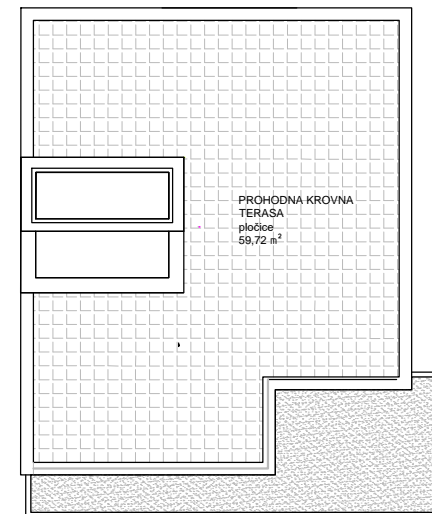

ISKAZ POVRŠINA KUĆA ISTOK						
Prostorija	Netto (m <sup>2</sup> )	Koef.	NKP (m <sup>2</sup> )	Brutto (m <sup>2</sup> )	GBP (m <sup>2</sup> )	
PRIZEMLJE	Hodnik	4,41	1	4,41		
	Wc	2,75	1	2,75		
	Soba 1	8,50	1	8,50		
	Kuhinja	6,96	1	6,96	68	68
	Blagovaonica	8,66	1	8,66		
	Dnevni boravak	20,17	1	20,17		
	Ostava	1,93	1	1,93		
	Stepenište	4,50	1	4,50		
1. KAT	Stepenište/hodnik	8,68	1	8,68		
	Soba 2	13,68	1	13,68		
	Soba 3	11,55	1	11,55		
	Kupaonica 1	5,25	1	5,25	68	68
	Kupaonica 2	4,77	1	4,77		
	Soba 4	10,23	1	10,23		
	Balkon	9,08	1	9,08		
	Stepenište	4,50	1	4,50		
KROV	Krovna terasa nenatkriv	59,72	0,25	14,93	68	-
	popločana terasa u vrtu	73,72	0,2	14,74		
VRT	vrt	104,00	0,1	10,40		
	Bazen	25,55	0,25	6,39	31,08	-
PARKING	2x parkirna mjesta	25,00	0,2	5,00		
	<b>Ukupno prizemlje:</b>	<b>413,61</b>		<b>177,08</b>	<b>235,08</b>	<b>136,00</b>



































